

CE EMC Test Report

Report No.: CE181225C15A

Test Model: SV240-25 2TB

Series Model: SX240-25 Y (X=A~Z, Y=10GB~2TB)

Received Date: Dec. 25, 2018

Test Date: Dec. 28, 2018 ~ Jan. 04, 2019

Issued Date: Feb. 04, 2020

Applicant: Apacer Technology Inc.

Address: 1F., No.32, Zhongcheng Rd., Tucheng Dist., New Taipei City 236, Taiwan

Issued By: Bureau Veritas Consumer Products Services (H.K.) Ltd., Taoyuan Branch
Lin Kou Laboratories

Lab Address: No. 47-2, 14th Ling, Chia Pau Vil., Lin Kou Dist., New Taipei City, Taiwan

Test Location : No. 19, Hwa Ya 2nd Rd., Wen Hwa Vil., Kwei Shan Dist., Taoyuan City
33383, TAIWAN



This report is for your exclusive use. Any copying or replication of this report to or for any other person or entity, or use of our name or trademark, is permitted only with our prior written permission. This report sets forth our findings solely with respect to the test samples identified herein. The results set forth in this report are not indicative or representative of the quality or characteristics of the lot from which a test sample was taken or any similar or identical product unless specifically and expressly noted. Our report includes all of the tests requested by you and the results thereof based upon the information that you provided to us. You have 60 days from date of issuance of this report to notify us of any material error or omission caused by our negligence, provided, however, that such notice shall be in writing and shall specifically address the issue you wish to raise. A failure to raise such issue within the prescribed time shall constitute your unqualified acceptance of the completeness of this report, the tests conducted and the correctness of the report contents. Unless specific mention, the uncertainty of measurement has been explicitly taken into account to declare the compliance or non-compliance to the specification. The report must not be used by the client to claim product certification, approval, or endorsement by A2LA or any agency of the U.S. Government. The report must not be used by the client to claim product certification, approval, or endorsement by TAF or any government agencies.

Table of Contents

Release Control Record	4
1 Certificate of Conformity	5
2 Summary of Test Results	6
2.1 Measurement Uncertainty	7
2.2 Modification Record.....	7
3 General Information	8
3.1 Description of EUT	8
3.2 Features of EUT	8
3.3 Operating Modes of EUT and Determination of Worst Case Operating Mode	9
3.4 Test Program Used and Operation Descriptions.....	9
3.5 Primary Clock Frequencies of Internal Source.....	9
3.6 Miscellaneous.....	10
4 Configuration and Connections with EUT	11
4.1 Connection Diagram of EUT and Peripheral Devices	11
4.2 Configuration of Peripheral Devices and Cable Connections	12
5 Conducted Emission from the AC Mains Power Port	13
5.1 Limits	13
5.2 Test Instruments	13
5.3 Test Arrangement	14
5.4 Test Results.....	15
6 Radiated Emission at Frequencies up to 1GHz	19
6.1 Limits	19
6.2 Test Instruments	19
6.3 Test Arrangement	20
6.4 Test Results.....	21
7 Radiated Emission at Frequencies above 1GHz	23
7.1 Limits	23
7.2 Test Instruments	24
7.3 Test Arrangement	25
7.4 Supplementary Information	25
7.5 Test Results.....	26
8 General Immunity Requirements	28
8.1 Performance Criteria	28
9 Electrostatic Discharge Immunity Test (ESD)	29
9.1 Test Specification	29
9.2 Test Instruments	29
9.3 Test Arrangement	29
9.4 Test Results.....	31
10 Radiated, Radio-frequency, Electromagnetic Field Immunity Test (RS)	33
10.1 Test Specification	33
10.2 Test Instruments	33
10.3 Test Arrangement	34
10.4 Test Results.....	34
11 Power Frequency Magnetic Field Immunity Test	35
11.1 Test Specification	35
11.2 Test Instruments	35

11.3	Test Arrangement	35
11.4	Test Results	36
12	Pictures of Test Arrangements	37
12.1	Conducted Emission from the AC Mains Power Port.....	37
12.2	Radiated Emission at Frequencies up to 1GHz	38
12.3	Radiated Emission at Frequencies above 1GHz	39
12.4	Electrostatic Discharge Immunity Test (ESD)	40
12.5	Radio-frequency, Electromagnetic Field Immunity Test (RS).....	40
12.6	Power Frequency Magnetic Field Immunity Test (PFMF)	41
	Appendix – Information of the Testing Laboratories	42

Release Control Record

Issue No.	Description	Date Issued
CE181225C15A	Original release.	Feb. 04, 2020

1 Certificate of Conformity

Product: Serial ATA Flash Drive
Brand: Apacer
Test Model: SV240-25 2TB
Series Model: SX240-25 Y (X=A~Z, Y=10GB~2TB)
Sample Status: Engineering sample
Applicant: Apacer Technology Inc.
Test Date: Dec. 28, 2018 ~ Jan. 04, 2019
Standards: **EN 55032:2012 +AC:2013 / EN 55032:2015 +AC:2016, Class B**
CISPR 32:2012 +Cor 2/ CISPR 32:2015 +CORR.1:2016, Class B
AS/NZS CISPR 32:2015, Class B
EN 61000-3-2:2014 / IEC 61000-3-2:2014 ED. 4.0 (Not applicable)
EN 61000-3-3:2013 / IEC 61000-3-3:2013 ED. 3.0 (Not applicable)
EN 55024:2010 +A1:2015 / CISPR 24:2010 +A1:2015
EN 61000-4-2:2009 / IEC 61000-4-2:2008 ED. 2.0
EN 61000-4-3:2006 +A1:2008 +A2:2010 / IEC 61000-4-3:2010 ED. 3.2
EN 61000-4-4:2012 / IEC 61000-4-4:2012 ED. 3.0 (Not applicable)
EN 61000-4-5:2014 +A1:2017 / IEC 61000-4-5:2014 +A1:2017 ED. 3.0 (Not applicable)
EN 61000-4-6:2014 +AC:2015 / IEC 61000-4-6:2013 ED. 4.0 (Not applicable)
EN 61000-4-8:2010 / IEC 61000-4-8:2009 ED. 2.0
EN 61000-4-11:2004 +A1:2017 / IEC 61000-4-11:2004 +A1:2017 ED. 2.0
(Not applicable)

The above equipment has been tested by **Bureau Veritas Consumer Products Services (H.K.) Ltd., Taoyuan Branch**, and found compliance with the requirement of the above standards. The test record, data evaluation & Equipment Under Test (EUT) configurations represented herein are true and accurate accounts of the measurements of the sample's EMC characteristics under the conditions specified in this report.

Prepared by : Sherry Wu, **Date:** Feb. 04, 2020
Sherry Wu / Specialist

Approved by : Carl Chen, **Date:** Feb. 04, 2020
Carl Chen / Project Engineer

2 Summary of Test Results

EN 55032, CISPR 32, Emission				
Standard	Clause	Test Item	Result/Remarks	Verdict
EN 55032:2012 +AC:2013/ EN 55032:2015 +AC:2016/ CISPR 32:2012 +Cor2/ CISPR 32:2015 +Cor1:2016/ AS/NZS CISPR 32:2015	A.3	Conducted emission from the AC mains power port	Minimum passing Class B margin is -11.54dB at 10.27500MHz	Pass
	A.3	Asymmetric mode conducted emission at wired network ports	Without wired network port of the EUT	N/A
	A.2	Radiated emission 30-1000 MHz	Minimum passing Class B margin is -4.12dB at 663.05MHz	Pass
	A.2	Radiated emission above 1GHz	Minimum passing Class B margin is -14.96dB at 2399.46MHz	Pass
EN 61000-3-2:2014 / IEC 61000-3-2:2014 ED. 4.0	-	Harmonic current emissions	Test not applicable because port does not exists	N/A
EN 61000-3-3:2013 / IEC 61000-3-3:2013 ED. 3.0	-	Voltage fluctuations and flicker	Test not applicable because port does not exists	N/A

EN 55024, Immunity

EN 55024 Clause	Basic standard	Test Item	Result/Remarks	Verdict
4.2.1	EN 61000-4-2:2009 / IEC 61000-4-2:2008 ED. 2.0	Electrostatic discharges (ESD)	Performance Criterion A	Pass
4.2.3.2	EN 61000-4-3:2006 +A1:2008 +A2:2010 / IEC 61000-4-3:2010 ED. 3.2	Continuous radiated disturbances (RS)	Performance Criterion A	Pass
4.2.2	EN 61000-4-4:2012 / IEC 61000-4-4:2012 ED. 3.0	Electrical fast transients (EFT)	EUT's cable length is not greater than 3m and EUT consumes DC power	N/A
4.2.5	EN 61000-4-5:2014 +A1:2017 / IEC 61000-4-5:2014 +A1:2017 ED. 3.0	Surges	EUT doesn't connect directly to outdoor cables and EUT consumes DC power	N/A
4.2.3.3	EN 61000-4-6:2014 +AC:2015 / IEC 61000-4-6:2013 ED. 4.0	Continuous conducted disturbances (CS)	EUT's cable length is not greater than 3m and EUT consumes DC power	N/A
4.2.4	EN 61000-4-8:2010 / IEC 61000-4-8:2009 ED. 2.0	Power-frequency magnetic fields (PFMF)	Performance Criterion A	Pass
4.2.6	EN 61000-4-11:2004 +A1:2017 / IEC 61000-4-11:2004 +A1:2017 ED. 2.0	Voltage dips and interruptions	Test not applicable because AC power port does not exist	N/A

Note:

1. There is no deviation to the applied test methods and requirements covered by the scope of this report.
2. Determining compliance based on the results of the compliance measurement, not taking into account measurement instrumentation uncertainty.
3. N/A: Not Applicable

2.1 Measurement Uncertainty

Where relevant, the following measurement uncertainty levels have been estimated for tests performed on the EUT as specified in CISPR 16-4-2:

Measurement	Expanded Uncertainty (k=2) (\pm)	Maximum allowable uncertainty (\pm)
Conducted emission from the AC mains power port using AMN, 150kHz ~ 30MHz	2.94 dB	3.4 dB (U_{cispr})
Radiated emission, 30MHz ~ 1GHz	4.14 dB	6.3 dB (U_{cispr})
Radiated emission, 1GHz ~ 6GHz	4.72 dB	5.2 dB (U_{cispr})

2.2 Modification Record

There were no modifications required for compliance.

3 General Information

3.1 Description of EUT

Product	Serial ATA Flash Drive
Brand	Apacer
Test Model	SV240-25 2TB
Series Model	SX240-25 Y (X=A~Z, Y=10GB~2TB)
Model Difference	Refer to note
Sample Status	Engineering sample
Operating Software	N/A
Power Supply Rating	5Vdc, 1.5A
Accessory Device	N/A
Data Cable Supplied	N/A

Note:

1. This report is issued as a duplicate report of BV CPS report no.: CE181225C15. The difference compared with original report is changing series model names. Due to no effect on any test item and we didn't re-test.
2. The following models are provided to this EUT.

Brand	Model	Description
Apacer	SV240-25 2TB	Main test model
	SX240-25 Y (X=A~Z, Y=10GB~2TB)	Series model for different capacity

* The model of the SV240-25 2TB was chosen for final test.

3.2 Features of EUT

The tests reported herein were performed according to the method specified by Apacer Technology Inc., for detailed feature description, please refer to the manufacturer's specifications or user's manual.

3.3 Operating Modes of EUT and Determination of Worst Case Operating Mode

The EUT consumes power from host, which designed with AC power supply of rating 100-240Vac, 50/60Hz.

For radiated emission up to 1GHz evaluation, 230Vac/50Hz & 110Vac/60Hz (for EN 55032 & AS/NZS CISPR 32), 120Vac/60Hz (for FCC Part 15 & ICES-003), 100Vac/50Hz&60Hz (for VCCI) and 110Vac/60Hz (for CNS 13438) had been covered during the pre-test. The worst data was found at 110Vac/60Hz and recorded in the applied test report.

For radiated emission up to 1GHz test, the EUT has been pre-tested under the following test modes, and test mode 1 was the worst case for final test.

Mode	Test Condition
1	EUT with System run R/W, 110Vac/60Hz
2	EUT with System run R/W, 230Vac/50Hz
3	EUT with System run R/W, 120Vac/60Hz
4	EUT with System run R/W, 100Vac/60Hz
5	EUT with System run R/W, 100Vac/50Hz

Test modes are presented in the report as below.

Mode	Test Condition
Conducted emission from the AC mains power port test	
-	EUT with System run R/W
Radiated emission up to 1GHz test	
-	EUT with System run R/W
Radiated emission above 1GHz test	
-	EUT with System run R/W
Immunity tests	
-	EUT with System run R/W

3.4 Test Program Used and Operation Descriptions

Emission tests:

- a. The EUT was installed in the PC.
- b. The PC ran a read & write test program to exercise EUT.
- c. The PC ran a read & write messages from/to ext. USB Floppy.
- d. The PC sent "ITU 471-1" patterns to the monitor and the monitor displayed them.
- e. The PC sent messages to printer and printer printed them out.

Immunity tests:

- a. The EUT was installed in the Notebook.
- b. The Notebook ran a read & write test program to exercise EUT.
- c. The Notebook sent "H" patterns to LCD panel and the LCD panel displayed them.

3.5 Primary Clock Frequencies of Internal Source

The highest frequency generated or used within the EUT or on which the EUT operates or tunes is 6GHz, provided by Apacer Technology Inc., for detailed internal source, please refer to the manufacturer's specifications.

3.6 Miscellaneous

➤ Affix CE marking

The marking must be placed visibly and legibly on the product or, if not possible due to the nature of the product, be affixed to the packaging and the accompanying document. The CE marking shall consist of the initials 'CE' taking the following form:

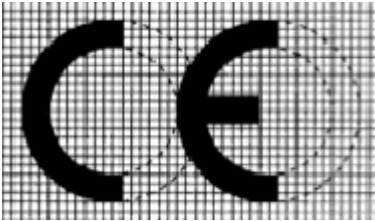

The various components of the CE marking must have the same vertical dimension, and may not be smaller than 5 mm. If the CE marking is reduced or enlarged, the proportions given in the graduated drawing above must be respected.

When the product is subject to other Directives covering other aspects and which also provide for the 'CE' marking, the accompanying documents must indicate that the product also conforms to those other Directives.

However, when one or more of those Directives allow the manufacturer, during a transitional period, to choose which arrangements to apply, the 'CE' marking has to indicate conformity only with the Directives applied by the manufacturer. In this case, the particularities of the Directives applied, as published in the Official Journal of the European Union, must be given in the documents, notices or instructions required by the Directives and accompanying such products.

4 Configuration and Connections with EUT

4.1 Connection Diagram of EUT and Peripheral Devices

Emission tests:

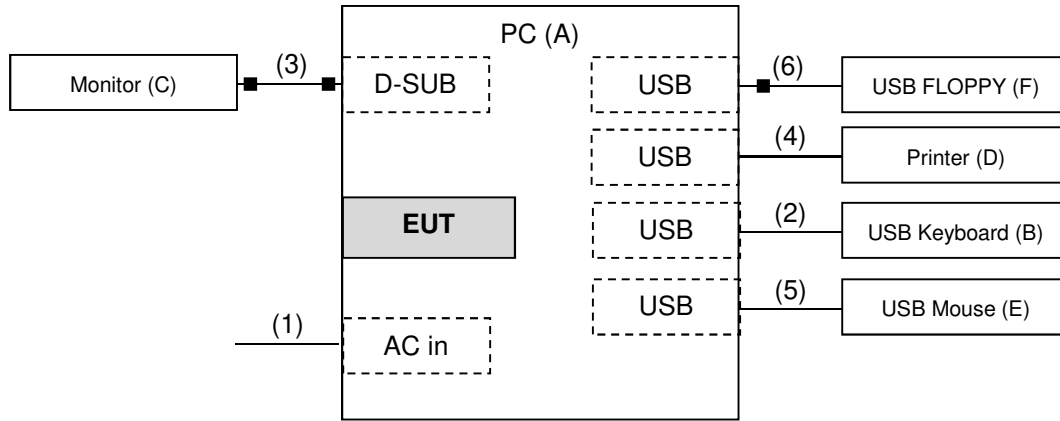

Immunity tests:

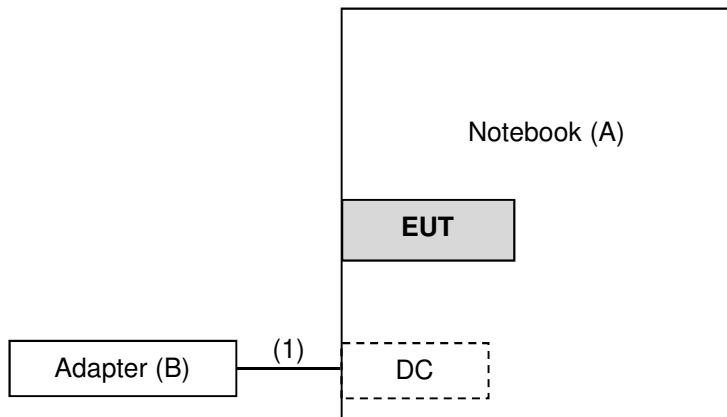

4.2 Configuration of Peripheral Devices and Cable Connections

Emission tests:

ID	Product	Brand	Model No.	Serial No.	FCC ID	Remarks
A.	DELL PC	DELL	OPTIPLEX 9020	9FDDJY1	FCC DoC Approved	-
B.	USB Keyboard	DELL	KB216t	CN-0W33XP-LO300-79R-OUG5-A03	FCC DoC Approved	-
C.	24" LCD MONITOR	DELL	U2410	CN082WXD-72872-0CR-06DL	FCC DoC Approved	-
D.	USB PRINTER	EPSON	T22	MEEZ070220	FCC DoC Approved	-
E.	USB Mouse	DELL	MOCZUL	CN-049TWY-PRC00-79E-02GB	FCC DoC Approved	-
F.	EXTERNAL USB 1.1 FLOPPY	SONY	MPF82E	50010254	FCC DoC Approved	-

Note: All power cords of the above support units are non-shielded (1.8m).

ID	Cable Descriptions	Qty.	Length (m)	Shielding (Yes/No)	Cores (Qty.)	Remarks
1.	Power Cable	1	1.8	N	0	-
2.	USB Cable	1	1.8	Y	0	-
3.	D-SUB Cable	1	1.8	Y	2	-
4.	USB Cable	1	1.8	Y	0	-
5.	USB Cable	1	1.8	Y	0	-
6.	USB Cable	1	0.5	Y	1	-

Note: The core(s) is(are) originally attached to the cable(s).

Immunity tests:

ID	Product	Brand	Model No.	Serial No.	FCC ID	Remarks
A.	PC	DELL	P60F	98JKMQ2	FCC DoC Approved	-
B.	Adapter	DELL	NA	NA	NA	-

Note: All power cords of the above support units are non-shielded (1.8m).

ID	Cable Descriptions	Qty.	Length (m)	Shielding (Yes/No)	Cores (Qty.)	Remarks
1.	Power Cable	1	1.8	N	0	Attached on adapter

Note: The core(s) is(are) originally attached to the cable(s).

5 Conducted Emission from the AC Mains Power Port

5.1 Limits

Frequency (MHz)	Class A (dBuV)		Class B (dBuV)	
	Quasi-peak	Average	Quasi-peak	Average
0.15 - 0.5	79	66	66 - 56	56 - 46
0.50 - 5.0	73	60	56	46
5.0 - 30.0	73	60	60	50

Notes: 1. The lower limit shall apply at the transition frequencies.
 2. The limit decreases linearly with the logarithm of the frequency in the range of 0.15 to 0.50 MHz.

5.2 Test Instruments

Description & Manufacturer	Model No.	Serial No.	Cal. Date	Cal. Due
Test Receiver ROHDE & SCHWARZ	ESCS 30	100288	Feb. 08, 2018	Feb. 07, 2019
RF signal cable (with 10dB PAD) Woken	5D-FB	Cable-cond2-01	Sep. 05, 2018	Sep. 04, 2019
AMN ROHDE & SCHWARZ (EUT)	ESH2-Z5	100100	Feb. 05, 2018	Feb. 04, 2019
AMN ROHDE & SCHWARZ (Peripheral)	ESH3-Z5	100312	Aug. 13, 2018	Aug. 12, 2019
Software ADT	BV ADT_Cond_ V7.3.7.4	NA	NA	NA

Note: 1. The calibration interval of the above test instruments is 12 months and the calibrations are traceable to NML/ROC and NIST/USA.
 2. The test was performed in HwaYa Shielded Room 2.
 3. The VCCI Site Registration No. is C-2047.

5.3 Test Arrangement

- The EUT was placed 0.4 meters from the conducting wall of the shielded room with EUT being connected to the power mains through an Artificial Mains Network (AMN). Other support units were connected to the power mains through another AMN. The two AMNs provide 50 Ohm/ 50uH of coupling impedance for the measuring instrument.
- Both lines of the power mains connected to the EUT were checked for maximum conducted interference.
- The test results of conducted emissions at mains ports are recorded of six worst margins for quasi-peak (mandatory) [and average (if necessary)] values against the limits at frequencies of interest unless the margin is 20 dB or greater.

Note: The resolution bandwidth and video bandwidth of test receiver is 9kHz for quasi-peak detection (QP) and average detection (AV) at frequency 0.15MHz-30MHz.

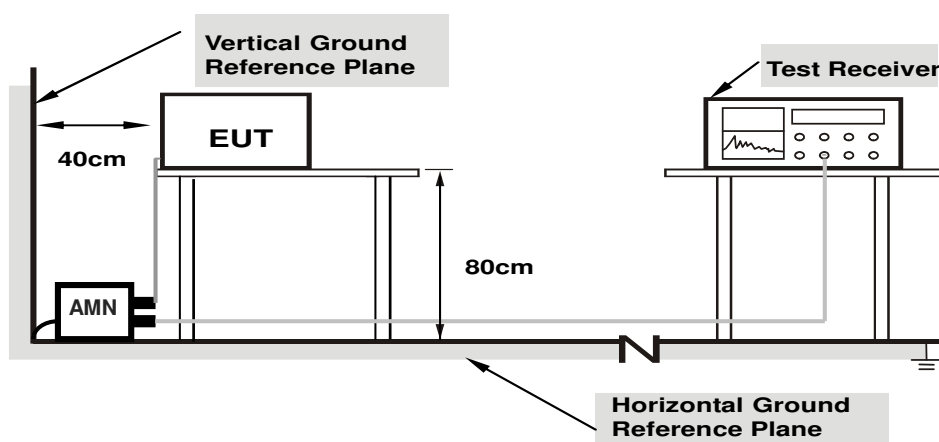

- Note:
- Support units were connected to second AMN.
 - The distance specified between EUT/AE and other metallic objects is ≥ 0.8 m in the measurement arrangement for table-top EUT.
 - According to EN 55032 & CISPR 32 standard, cables on the RGP must be insulated.

5.4 Test Results

Frequency Range	150kHz ~ 30MHz	Detector Function & Bandwidth	Quasi-Peak (QP) / Average (AV), 9kHz
Input Power (System)	110Vac, 60Hz	Environmental Conditions	25°C, 65%RH
Tested by	Daniel Lin	Test Date	2018/12/28

Phase Of Power : Line (L)										
No	Frequency (MHz)	Correction Factor (dB)	Reading Value (dBuV)		Emission Level (dBuV)		Limit (dBuV)		Margin (dB)	
			Q.P.	AV.	Q.P.	AV.	Q.P.	AV.	Q.P.	AV.
1	0.54357	10.06	26.13	15.55	36.19	25.61	56.00	46.00	-19.81	-20.39
2	0.87893	10.07	26.41	17.03	36.48	27.10	56.00	46.00	-19.52	-18.90
3	1.28400	10.07	26.75	14.24	36.82	24.31	56.00	46.00	-19.18	-21.69
4	3.21225	10.12	25.14	12.89	35.26	23.01	56.00	46.00	-20.74	-22.99
5	10.27500	10.30	35.92	28.16	46.22	38.46	60.00	50.00	-13.78	-11.54
6	11.83650	10.34	30.66	25.40	41.00	35.74	60.00	50.00	-19.00	-14.26

Remarks:

1. Q.P. and AV. are abbreviations of quasi-peak and average individually.
2. The emission levels of other frequencies were very low against the limit.
3. Margin value = Emission level – Limit value
4. Correction factor = Insertion loss + Cable loss
5. Emission Level = Correction Factor + Reading Value

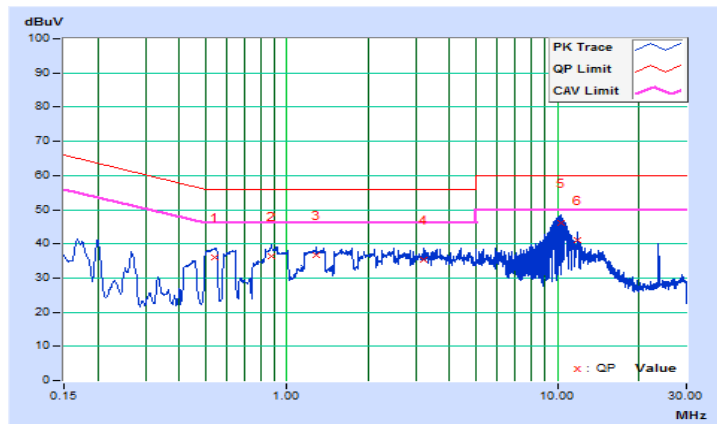

Frequency Range	150kHz ~ 30MHz	Detector Function & Bandwidth	Quasi-Peak (QP) / Average (AV), 9kHz
Input Power (System)	110Vac, 60Hz	Environmental Conditions	25°C, 65%RH
Tested by	Daniel Lin	Test Date	2018/12/28

Phase Of Power : Neutral (N)										
No	Frequency (MHz)	Correction Factor (dB)	Reading Value (dBuV)		Emission Level (dBuV)		Limit (dBuV)		Margin (dB)	
			Q.P.	AV.	Q.P.	AV.	Q.P.	AV.	Q.P.	AV.
1	0.16800	10.06	31.02	23.50	41.08	33.56	65.06	55.06	-23.98	-21.50
2	0.19983	10.07	29.44	22.06	39.51	32.13	63.62	53.62	-24.11	-21.49
3	0.87893	10.08	23.30	13.05	33.38	23.13	56.00	46.00	-22.62	-22.87
4	3.21000	10.14	23.17	13.36	33.31	23.50	56.00	46.00	-22.69	-22.50
5	11.83650	10.42	30.23	25.04	40.65	35.46	60.00	50.00	-19.35	-14.54
6	23.69400	10.56	27.92	23.74	38.48	34.30	60.00	50.00	-21.52	-15.70

Remarks:

1. Q.P. and AV. are abbreviations of quasi-peak and average individually.
2. The emission levels of other frequencies were very low against the limit.
3. Margin value = Emission level – Limit value
4. Correction factor = Insertion loss + Cable loss
5. Emission Level = Correction Factor + Reading Value

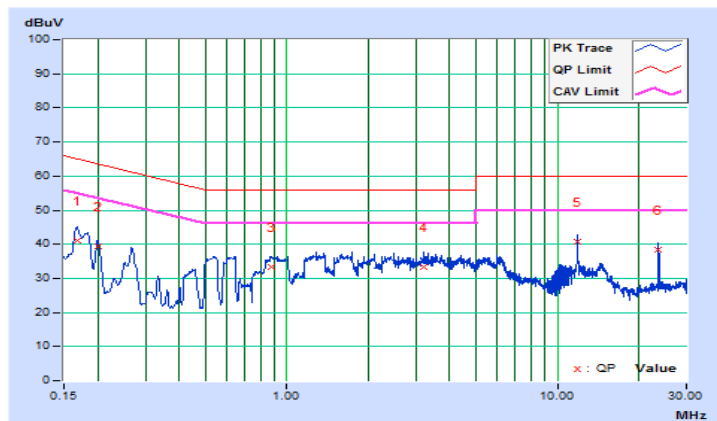

Frequency Range	150kHz ~ 30MHz	Detector Function & Bandwidth	Quasi-Peak (QP) / Average (AV), 9kHz
Input Power (System)	230Vac, 50Hz	Environmental Conditions	25°C, 65%RH
Tested by	Daniel Lin	Test Date	2018/12/28

Phase Of Power : Line (L)										
No	Frequency (MHz)	Correction Factor (dB)	Reading Value (dBuV)		Emission Level (dBuV)		Limit (dBuV)		Margin (dB)	
			Q.P.	AV.	Q.P.	AV.	Q.P.	AV.	Q.P.	AV.
1	0.54501	10.06	26.24	15.51	36.30	25.57	56.00	46.00	-19.70	-20.43
2	0.87893	10.07	26.42	17.01	36.49	27.08	56.00	46.00	-19.51	-18.92
3	1.28400	10.07	26.70	14.29	36.77	24.36	56.00	46.00	-19.23	-21.64
4	3.66900	10.14	24.92	15.87	35.06	26.01	56.00	46.00	-20.94	-19.99
5	9.89250	10.29	34.89	27.38	45.18	37.67	60.00	50.00	-14.82	-12.33
6	11.83425	10.34	30.53	24.19	40.87	34.53	60.00	50.00	-19.13	-15.47

Remarks:

1. Q.P. and AV. are abbreviations of quasi-peak and average individually.
2. The emission levels of other frequencies were very low against the limit.
3. Margin value = Emission level – Limit value
4. Correction factor = Insertion loss + Cable loss
5. Emission Level = Correction Factor + Reading Value

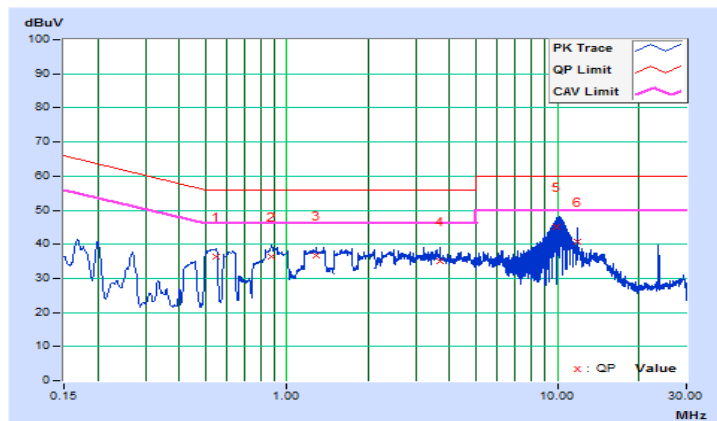

Frequency Range	150kHz ~ 30MHz	Detector Function & Bandwidth	Quasi-Peak (QP) / Average (AV), 9kHz
Input Power (System)	230Vac, 50Hz	Environmental Conditions	25°C, 65%RH
Tested by	Daniel Lin	Test Date	2018/12/28

Phase Of Power : Neutral (N)										
No	Frequency (MHz)	Correction Factor (dB)	Reading Value (dBuV)		Emission Level (dBuV)		Limit (dBuV)		Margin (dB)	
			Q.P.	AV.	Q.P.	AV.	Q.P.	AV.	Q.P.	AV.
1	0.16655	10.06	30.50	22.08	40.56	32.14	65.13	55.13	-24.57	-22.99
2	0.19983	10.07	29.76	22.42	39.83	32.49	63.62	53.62	-23.79	-21.13
3	0.54600	10.07	23.37	13.34	33.44	23.41	56.00	46.00	-22.56	-22.59
4	3.33825	10.14	23.02	14.23	33.16	24.37	56.00	46.00	-22.84	-21.63
5	11.83650	10.42	28.84	23.64	39.26	34.06	60.00	50.00	-20.74	-15.94
6	23.69400	10.56	28.03	22.84	38.59	33.40	60.00	50.00	-21.41	-16.60

Remarks:

1. Q.P. and AV. are abbreviations of quasi-peak and average individually.
2. The emission levels of other frequencies were very low against the limit.
3. Margin value = Emission level – Limit value
4. Correction factor = Insertion loss + Cable loss
5. Emission Level = Correction Factor + Reading Value

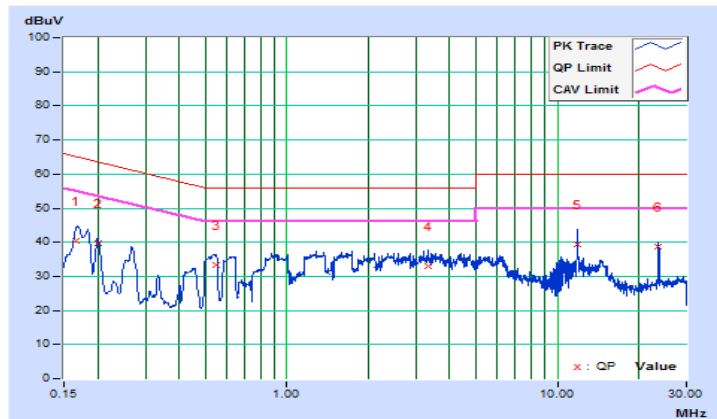

6 Radiated Emission at Frequencies up to 1GHz

6.1 Limits

Frequency (MHz)	Class A (dBuV/m)		Class B (dBuV/m)	
	at 10m	at 3m	at 10m	at 3m
30 - 230	40	50	30	40
230 - 1000	47	57	37	47

- Notes:
1. The lower limit shall apply at the transition frequencies.
 2. Emission level (dBuV/m) = 20 log Emission level (uV/m).
 3. All emanations from a class A/B digital device or system, including any network of conductors and apparatus connected thereto, shall not exceed the level of field strengths specified above.

6.2 Test Instruments

Description & Manufacturer	Model No.	Serial No.	Cal. Date	Cal. Due
Test Receiver ROHDE & SCHWARZ (V)	ESR	101240	Oct. 30, 2018	Oct. 29, 2019
Test Receiver ROHDE & SCHWARZ (H)	ESR	101471	Mar. 01, 2018	Feb. 28, 2019
BILOG Antenna SCHWARZBECK (V)	VULB9168	9168-148	Nov. 20, 2018	Nov. 19, 2019
BILOG Antenna SCHWARZBECK (H)	VULB9168	9168-156	Nov. 20, 2018	Nov. 19, 2019
Preamplifier Sonoma (V)	310N	352924	Jul. 12, 2018	Jul. 11, 2019
Preamplifier Sonoma (H)	310N	352923	Jul. 12, 2018	Jul. 11, 2019
RF signal cable (with 5dB PAD) Times (V)	LMR-600 (18M) +LMR-400 (7M)	CABLE-CH1 (VER) -01	Oct. 03, 2018	Oct. 02, 2019
RF signal cable (with 5dB PAD) Times (H)	LMR-600 (11.8M) +LMR-400 (7M)	CABLE-CH1 (HOR) -01	Oct. 03, 2018	Oct. 02, 2019
Software BV ADT	BV ADT_Radiated_ V8.7.08	NA	NA	NA
Antenna Tower (V)	MFA-440	9707	NA	NA
Antenna Tower (H)	MFA-440	970705	NA	NA
Turn Table	DS430	50303	NA	NA
Controller (V)	MF7802	074	NA	NA
Controller (H)	MF7802	08093	NA	NA

- Note:
1. The calibration interval of the above test instruments is 12 months and the calibrations are traceable to NML/ROC and NIST/USA.
 2. The test was performed in HwaYa Chamber 1.
 3. The FCC Designation Number is TW1050. The number will be varied with the Lab location and scope as attached.
 4. The IC Site Registration No. is 7450F-1.
 5. The VCCI Site Registration No. is R-1893

6.3 Test Arrangement

- The EUT was placed on the top of a rotating table 0.8 meters above the ground at an accredited test facility. The table was rotated 360 degrees to determine the position of the highest radiation.
- The EUT was set 10 meters away from the interference-receiving antenna, which was mounted on the top of a variable-height antenna tower.
- The antenna is a broadband antenna, and its height is varied from one meter to four meters above the ground to determine the maximum value of the field strength. Both horizontal and vertical polarizations of the antenna are set to make the measurement.
- For each suspected emission, the EUT was arranged to its worst case and then the antenna was tuned to heights from 1 meter to 4 meters and the rotatable table was turned from 0 degrees to 360 degrees to find the maximum reading.
- The test-receiver system was set to quasi-peak detect function and specified bandwidth with maximum hold mode when the test frequency is up to 1 GHz.

Note: The resolution bandwidth and video bandwidth of test receiver/spectrum analyzer is 120kHz for quasi-peak detection (QP) at frequency up to 1GHz.

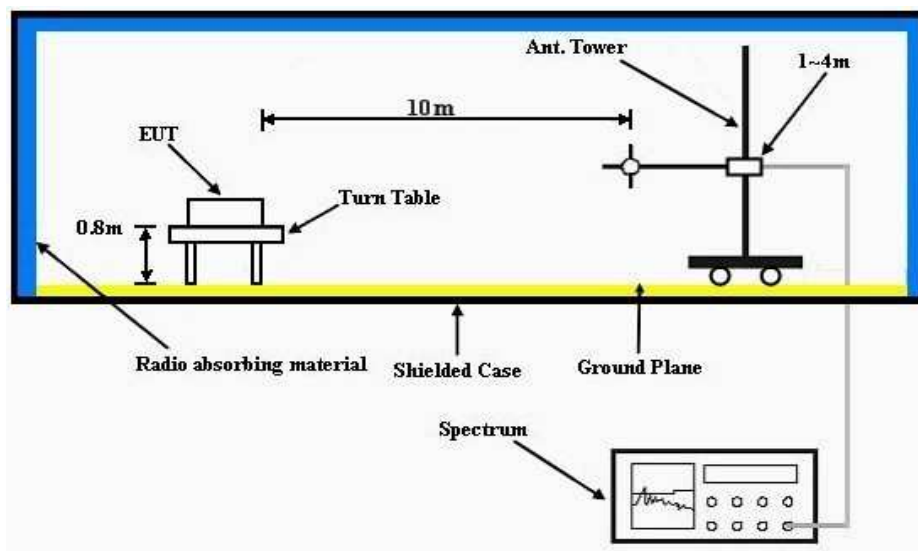

Note: According to EN 55032 & CISPR 32 standard, cables on the RGP must be

6.4 Test Results

Frequency Range	30MHz ~ 1GHz	Detector Function & Bandwidth	Quasi-Peak (QP), 120kHz
Tested by	Daniel Lin	Environmental Conditions	20°C, 62%RH
Test Date	2018/12/29		

Antenna Polarity & Test Distance : Horizontal at 10 m								
No	Frequency (MHz)	Emission Level (dBuV/m)	Limit (dBuV/m)	Margin (dB)	Antenna Height (m)	Table Angle (Degree)	Raw Value (dBuV)	Correction Factor (dB/m)
1	50.23	15.99 QP	30.00	-14.01	1.00 H	286	34.10	-18.11
2	154.80	18.37 QP	30.00	-11.63	1.50 H	34	36.05	-17.68
3	316.60	18.85 QP	37.00	-18.15	2.00 H	16	34.79	-15.94
4	605.09	26.82 QP	37.00	-10.18	1.50 H	11	36.83	-10.01
5	663.05	32.88 QP	37.00	-4.12	4.00 H	128	42.37	-9.49
6	690.18	32.67 QP	37.00	-4.33	1.00 H	50	41.86	-9.19

Remarks:

1. Emission Level(dBuV/m) = Raw Value(dBuV) + Correction Factor(dB/m)
2. Correction Factor(dB/m) = Antenna Factor (dB/m) + Cable Factor (dB)
– Pre-Amplifier Factor (dB)
3. The other emission levels were very low against the limit.
4. Margin value = Emission level – Limit value

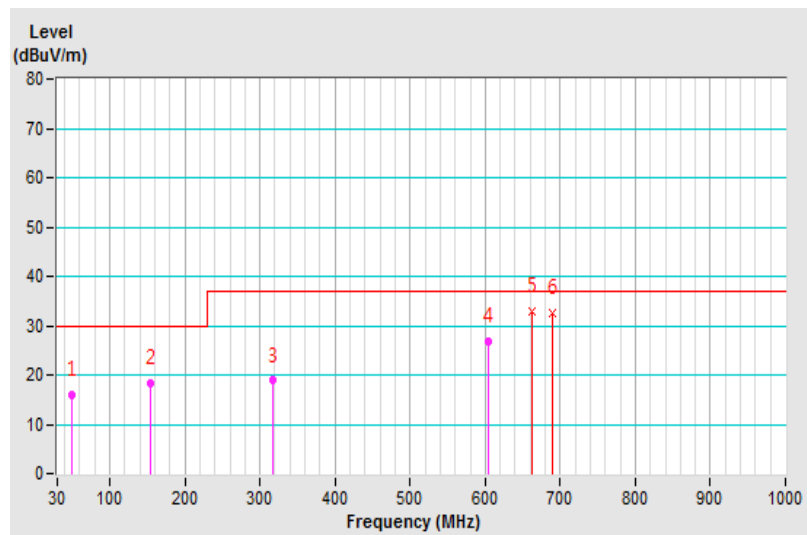

Frequency Range	30MHz ~ 1GHz	Detector Function & Bandwidth	Quasi-Peak (QP), 120kHz
Tested by	Daniel Lin	Environmental Conditions	20°C, 62%RH
Test Date	2018/12/29		

Antenna Polarity & Test Distance : Vertical at 10 m								
No	Frequency (MHz)	Emission Level (dBuV/m)	Limit (dBuV/m)	Margin (dB)	Antenna Height (m)	Table Angle (Degree)	Raw Value (dBuV)	Correction Factor (dB/m)
1	38.29	15.17 QP	30.00	-14.83	3.00 V	347	34.44	-19.27
2	49.93	15.28 QP	30.00	-14.72	3.50 V	1	33.54	-18.26
3	125.02	16.72 QP	30.00	-13.28	2.00 V	36	36.39	-19.67
4	149.12	20.47 QP	30.00	-9.53	1.00 V	209	38.14	-17.67
5	662.91	27.63 QP	37.00	-9.37	2.50 V	257	36.48	-8.85
6	690.07	27.95 QP	37.00	-9.05	4.00 V	341	36.58	-8.63

Remarks:

1. Emission Level(dBuV/m) = Raw Value(dBuV) + Correction Factor(dB/m)
2. Correction Factor(dB/m) = Antenna Factor (dB/m) + Cable Factor (dB)
– Pre-Amplifier Factor (dB)
3. The other emission levels were very low against the limit.
4. Margin value = Emission level – Limit value

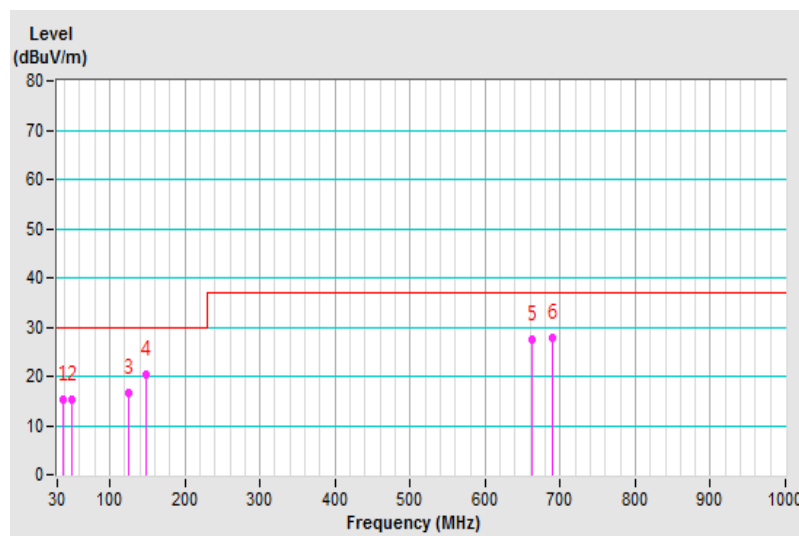

7 Radiated Emission at Frequencies above 1GHz

7.1 Limits

Frequency (GHz)	Class A (dBuV/m) (at 3m)		Class B (dBuV/m) (at 3m)	
	Average	Peak	Average	Peak
1 to 3	56	76	50	70
3 to 6	60	80	54	74

- Notes: 1. The lower limit shall apply at the transition frequencies.
 2. Emission level (dBuV/m) = 20 log Emission level (uV/m).
 3. All emanations from a class A/B digital device or system, including any network of conductors and apparatus connected thereto, shall not exceed the level of field strengths specified above.

Frequency Range (For unintentional radiators)

Highest frequency generated or used in the EUT or on which the EUT operates or tunes (MHz)	Upper frequency of measurement range (MHz)
Below 108	1000
108-500	2000
500-1000	5000
Above 1000	Up to 5 times of the highest frequency or 6 GHz, whichever is less

7.2 Test Instruments

Description & Manufacturer	Model No.	Serial No.	Cal. Date	Cal. Due
Test Receiver ROHDE & SCHWARZ (V)	ESR	101240	Oct. 30, 2018	Oct. 29, 2019
Test Receiver ROHDE & SCHWARZ (H)	ESR	101471	Mar. 01, 2018	Feb. 28, 2019
BILOG Antenna SCHWARZBECK (V)	VULB9168	9168-148	Nov. 20, 2018	Nov. 19, 2019
BILOG Antenna SCHWARZBECK (H)	VULB9168	9168-156	Nov. 20, 2018	Nov. 19, 2019
Preamplifier Sonoma (V)	310N	352924	Jul. 12, 2018	Jul. 11, 2019
Preamplifier Sonoma (H)	310N	352923	Jul. 12, 2018	Jul. 11, 2019
RF signal cable (with 5dB PAD) Times (V)	LMR-600 (18M) +LMR-400 (7M)	CABLE-CH1 (VER) -01	Oct. 03, 2018	Oct. 02, 2019
RF signal cable (with 5dB PAD) Times (H)	LMR-600 (11.8M) +LMR-400 (7M)	CABLE-CH1 (HOR) -01	Oct. 03, 2018	Oct. 02, 2019
Software BV ADT	BV ADT_Radiated_ V8.7.08	NA	NA	NA
Antenna Tower (V)	MFA-440	9707	NA	NA
Antenna Tower (H)	MFA-440	970705	NA	NA
Turn Table	DS430	50303	NA	NA
Controller (V)	MF7802	074	NA	NA
Controller (H)	MF7802	08093	NA	NA
HORN Antenna (with 4dB PAD) EMCO	3117	00034126	Nov. 25, 2018	Nov. 24, 2019
Preamplifier EMCI	EMC012645SE	980338	Jul. 02, 2018	Jul. 01, 2019
Spectrum Analyzer KEYSIGHT	N9030B	MY57141885	May 28, 2018	May 27, 2019
RF Coaxial Cable EMCI	EMC102-KM-KM- 1000	170820	Aug. 28, 2018	Aug. 27, 2019
RF Coaxial Cable EMCI	EMC102-KM-KM- 3000	150929	Aug. 28, 2018	Aug. 27, 2019
Fix tool for Boresight antenna	BAF-01	2	NA	NA

- Note: 1. The calibration interval of the above test instruments is 12 months and the calibrations are traceable to NML/ROC and NIST/USA.
2. The test was performed in HwaYa Chamber 1.
3. The FCC Site Registration No. is 477732.
4. The IC Site Registration No. is IC 7450F-1.
5. The VCCI Site Registration No. is G-113.
6. The 3dB beamwidth of the horn antenna is minimum 30 degree (or $w = 1.6\text{m}$ at 3m distance) for 1~6 GHz.

7.3 Test Arrangement

- The EUT was placed on the top of a rotating table 0.8 meters above the ground at an accredited chamber room. The table was rotated 360 degrees to determine the position of the highest radiation.
- The EUT was set 3 meters away from the interference-receiving antenna, which was mounted on the top of a variable-height antenna tower.
- The height of antenna can be varied from one meter to four meters, the height of adjustment depends on the EUT height and the antenna 3dB beamwidth both, to detect the maximum value of the field strength. Both horizontal and vertical polarizations of the antenna are set to make the measurement.
- For each suspected emission, the EUT was arranged to its worst case and then the antenna was tuned to heights and the rotatable table was turned from 0 degrees to 360 degrees to find the maximum reading.
- The spectrum analyzer system was set to peak and average detect function and specified bandwidth with maximum hold mode when the test frequency is above 1 GHz.

Note: The resolution bandwidth of test receiver/spectrum analyzer is 1MHz and video bandwidth is 3MHz for Peak detection (PK) at frequency above 1GHz. The resolution bandwidth of test receiver/spectrum analyzer is 1 MHz for Average detection (AV) at frequency above 1GHz.

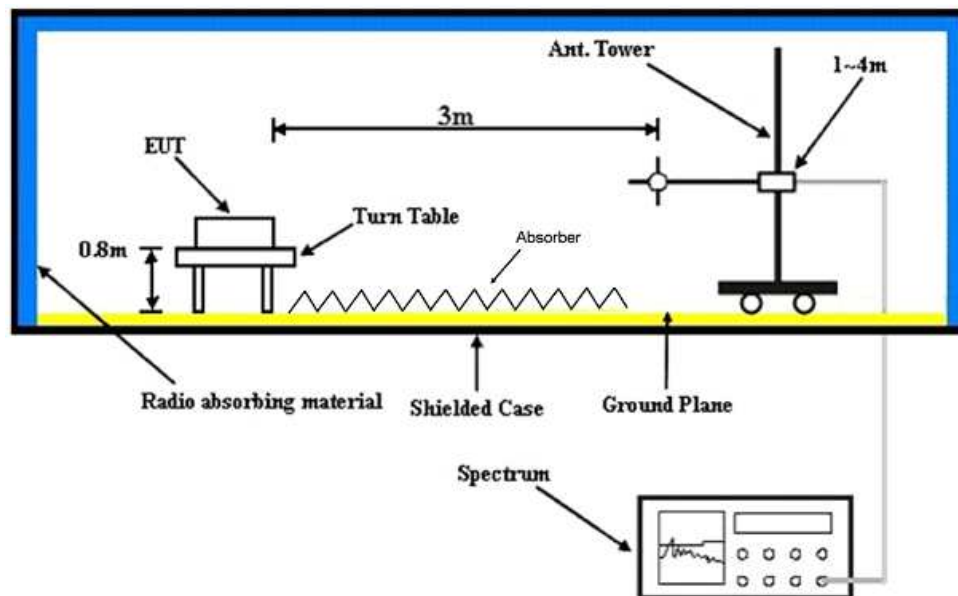

Note: According to EN 55032 & CISPR 32 standard, cables on the RGP must be insulated.

7.4 Supplementary Information

The more stringent measurement method of paragraph 8.3.2.2 in ANSI C63.4:2014 was applied for the test.

7.5 Test Results

Frequency Range	1GHz ~ 6GHz	Detector Function & Bandwidth	Peak (PK) / Average (AV), 1MHz
Tested by	Daniel Lin	Environmental Conditions	20°C, 72%RH
Test Date	2018/12/28		

Antenna Polarity & Test Distance : Horizontal at 3 m								
No	Frequency (MHz)	Emission Level (dBuV/m)	Limit (dBuV/m)	Margin (dB)	Antenna Height (m)	Table Angle (Degree)	Raw Value (dBuV)	Correction Factor (dB/m)
1	2399.46	50.21 PK	70.00	-19.79	1.24 H	262	45.71	4.50
2	2399.46	35.04 AV	50.00	-14.96	1.24 H	262	30.54	4.50
3	2999.54	52.54 PK	70.00	-17.46	1.24 H	193	47.36	5.18
4	2999.54	34.21 AV	50.00	-15.79	1.24 H	193	29.03	5.18
5	3149.17	53.12 PK	74.00	-20.88	1.32 H	313	47.81	5.31
6	3149.17	34.04 AV	54.00	-19.96	1.32 H	313	28.73	5.31
7	4785.27	49.16 PK	74.00	-24.84	1.00 H	359	41.23	7.93
8	4785.27	35.66 AV	54.00	-18.34	1.00 H	359	27.73	7.93
9	5413.38	46.53 PK	74.00	-27.47	1.49 H	317	37.76	8.77
10	5413.38	35.71 AV	54.00	-18.29	1.49 H	317	26.94	8.77
11	5998.14	50.96 PK	74.00	-23.04	1.98 H	285	41.54	9.42
12	5998.14	38.23 AV	54.00	-15.77	1.98 H	285	28.81	9.42

Remarks:

1. Emission Level(dBuV/m) = Raw Value(dBuV) + Correction Factor(dB/m)
2. Correction Factor(dB/m) = Antenna Factor (dB/m) + Cable Factor (dB) – Pre-Amplifier Factor (dB)
3. The other emission levels were very low against the limit.
4. Margin value = Emission level – Limit value

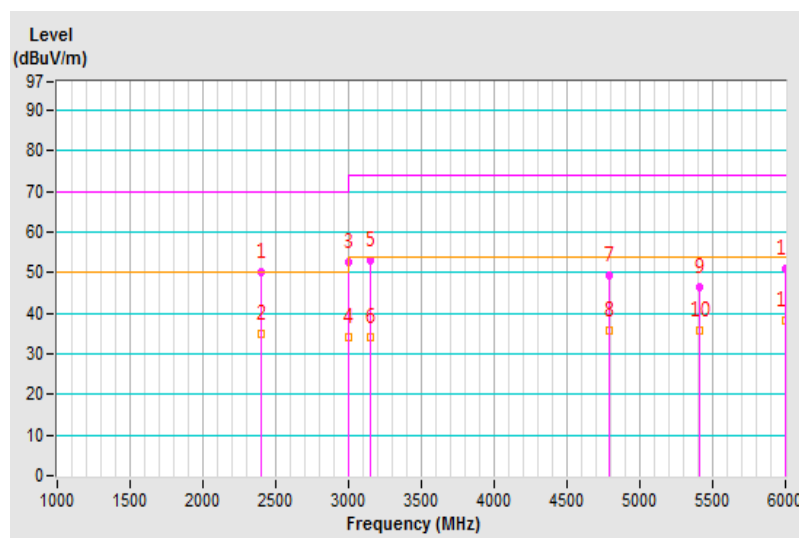

Frequency Range	1GHz ~ 6GHz	Detector Function & Bandwidth	Peak (PK) / Average (AV), 1MHz
Tested by	Daniel Lin	Environmental Conditions	20°C, 72%RH
Test Date	2018/12/28		

Antenna Polarity & Test Distance : Vertical at 3 m								
No	Frequency (MHz)	Emission Level (dBuV/m)	Limit (dBuV/m)	Margin (dB)	Antenna Height (m)	Table Angle (Degree)	Raw Value (dBuV)	Correction Factor (dB/m)
1	1286.90	42.89 PK	70.00	-27.11	1.43 V	7	42.76	0.13
2	1286.90	31.64 AV	50.00	-18.36	1.43 V	7	31.51	0.13
3	1720.91	41.99 PK	70.00	-28.01	2.00 V	175	41.24	0.75
4	1720.91	30.66 AV	50.00	-19.34	2.00 V	175	29.91	0.75
5	1999.42	48.00 PK	70.00	-22.00	2.05 V	313	43.43	4.57
6	1999.42	34.87 AV	50.00	-15.13	2.05 V	313	30.30	4.57
7	2999.02	50.72 PK	70.00	-19.28	1.50 V	22	45.54	5.18
8	2999.02	34.38 AV	50.00	-15.62	1.50 V	22	29.20	5.18
9	3149.01	52.86 PK	74.00	-21.14	1.00 V	317	47.55	5.31
10	3149.01	34.55 AV	54.00	-19.45	1.03 V	317	29.24	5.31
11	5999.95	53.87 PK	74.00	-20.13	1.05 V	9	44.44	9.43
12	5999.95	38.69 AV	54.00	-15.31	1.05 V	9	29.26	9.43

Remarks:

1. Emission Level(dBuV/m) = Raw Value(dBuV) + Correction Factor(dB/m)
2. Correction Factor(dB/m) = Antenna Factor (dB/m) + Cable Factor (dB) – Pre-Amplifier Factor (dB)
3. The other emission levels were very low against the limit.
4. Margin value = Emission level – Limit value

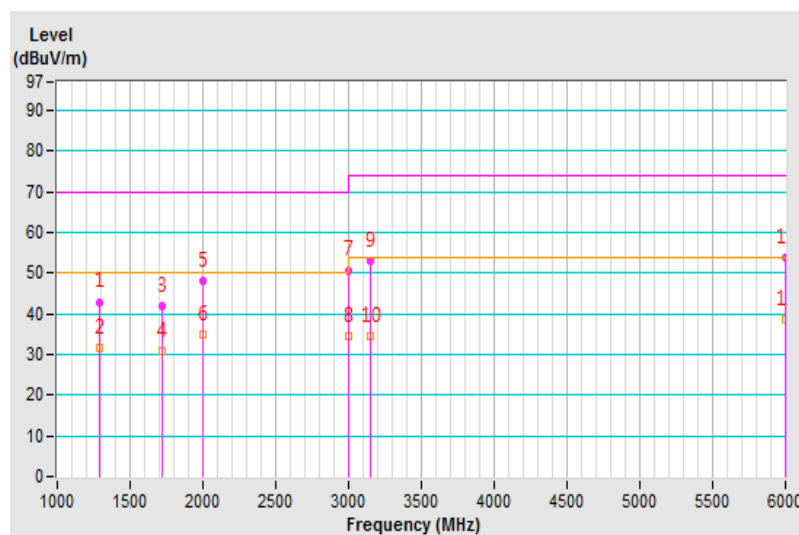

8 General Immunity Requirements

EN 55024:2010 +A1:2015, Immunity requirements				
Clause	Reference standard	Table	Test specification	Performance Criterion
4.2.1	EN 61000-4-2 ESD	1.3	Enclosure port: ±8kV Air discharge, ±4kV Contact discharge	B
4.2.3.2	EN 61000-4-3 RS	1.2	Enclosure port: 80-1000 MHz, 3V/m, 80% AM (1kHz)	A
4.2.4	EN 61000-4-8 PFMF	1.1	Enclosure port: 50 or 60 Hz, 1A/m	A

8.1 Performance Criteria

General Performance Criteria

Performance criterion A

The equipment shall continue to operate as intended without operator intervention. No degradation of performance or loss of function is allowed below a performance level specified by the manufacturer when the equipment is used as intended. The performance level may be replaced by a permissible loss of performance. If the minimum performance level or the permissible performance loss is not specified by the manufacturer, then either of these may be derived from the product description and documentation, and by what the user may reasonably expect from the equipment if used as intended.

Performance criterion B

After the test, the equipment shall continue to operate as intended without operator intervention. No degradation of performance or loss of function is allowed, after the application of the phenomena below a performance level specified by the manufacturer, when the equipment is used as intended. The performance level may be replaced by a permissible loss of performance. During the test, degradation of performance is allowed. However, no change of operating state or stored data is allowed to persist after the test. If the minimum performance level (or the permissible performance loss) is not specified by the manufacturer, then either of these may be derived from the product description and documentation, and by what the user may reasonably expect from the equipment if used as intended.

Performance criterion C

Loss of function is allowed, provided the function is self-recoverable, or can be restored by the operation of the controls by the user in accordance with the manufacturer's instructions. Functions, and/or information stored in non-volatile memory, or protected by a battery backup, shall not be lost.

9 Electrostatic Discharge Immunity Test (ESD)

9.1 Test Specification

Basic Standard:	EN/IEC 61000-4-2
Discharge Impedance:	330 ohm / 150 pF
Discharge Voltage:	Air Discharge: $\pm 2, \pm 4, \pm 8$ kV (Direct) Contact Discharge: $\pm 2, \pm 4$ kV (Direct / Indirect)
Number of Discharge:	Air – Direct: 10 discharges per location (each polarity) Contact – Direct & Indirect: 25 discharges per location (each polarity) and min. 200 times in total
Discharge Mode:	Single Discharge
Discharge Period:	1-second minimum

9.2 Test Instruments

Description & Manufacturer	Model No.	Serial No.	Cal. Date	Cal. Due
ELECTROSTATIC DISCHARGE (EMTEST)	Dito	V0701102114	Dec. 14, 2018	Dec. 13, 2019

- Note: 1. The test was performed in HwaYa ESD Room 1.
2. The calibration interval of the above test instruments is 12 months and the calibrations are traceable to NML/ROC and NIST/USA.

9.3 Test Arrangement

The discharges shall be applied in two ways:

- a. Contact discharges to the conductive surfaces and coupling planes:

The EUT shall be exposed to at least 200 discharges, 100 each at negative and positive polarity, at a minimum of four test points. One of the test points shall be subjected to at least 50 indirect discharges to the center of the front edge of the horizontal coupling plane. The remaining three test points shall each receive at least 50 direct contact discharges. If no direct contact test points are available, then at least 200 indirect discharges shall be applied in the indirect mode. Test shall be performed at a maximum repetition rate of one discharge per second.

- b. Air discharges at slots and apertures and insulating surfaces:

On those parts of the EUT where it is not possible to perform contact discharge testing, the equipment should be investigated to identify user accessible points where breakdown may occur. Such points are tested using the air discharge method. This investigation should be restricted to those area normally handled by the user. A minimum of 10 single air discharges shall be applied to the selected test point for each such area.

The basic test procedure was in accordance with EN/IEC 61000-4-2:

- a. Electrostatic discharges were applied only to those points and surfaces of the EUT that are accessible to users during normal operation.
- b. The test was performed with at least ten single discharges on the pre-selected points in the most sensitive polarity.
- c. The time interval between two successive single discharges was at least 1 second.
- d. The ESD generator was held perpendicularly to the surface to which the discharge was applied and the return cable was at least 0.2 meters from the EUT.
- e. Contact discharges were applied to the non-insulating coating, with the pointed tip of the generator penetrating the coating and contacting the conducting substrate.
- f. Air discharges were applied with the round discharge tip of the discharge electrode approaching the EUT as fast as possible (without causing mechanical damage) to touch the EUT. After each discharge, the ESD generator was removed from the EUT and re-triggered for a new single discharge. The test was repeated until all discharges were complete.
- g. At least ten single discharges (in the most sensitive polarity) were applied to the **Horizontal Coupling Plane** at points on each side of the EUT. The ESD generator was positioned at a distance of 0.1 meters from the EUT with the discharge electrode touching the **HCP**.
- h. At least ten single discharges (in the most sensitive polarity) were applied to the center of one vertical edge of the **Vertical Coupling Plane** in sufficiently different positions that the four faces of the EUT were completely illuminated. The **VCP** (dimensions 0.5m x 0.5m) was placed vertically to and 0.1 meters from the EUT.

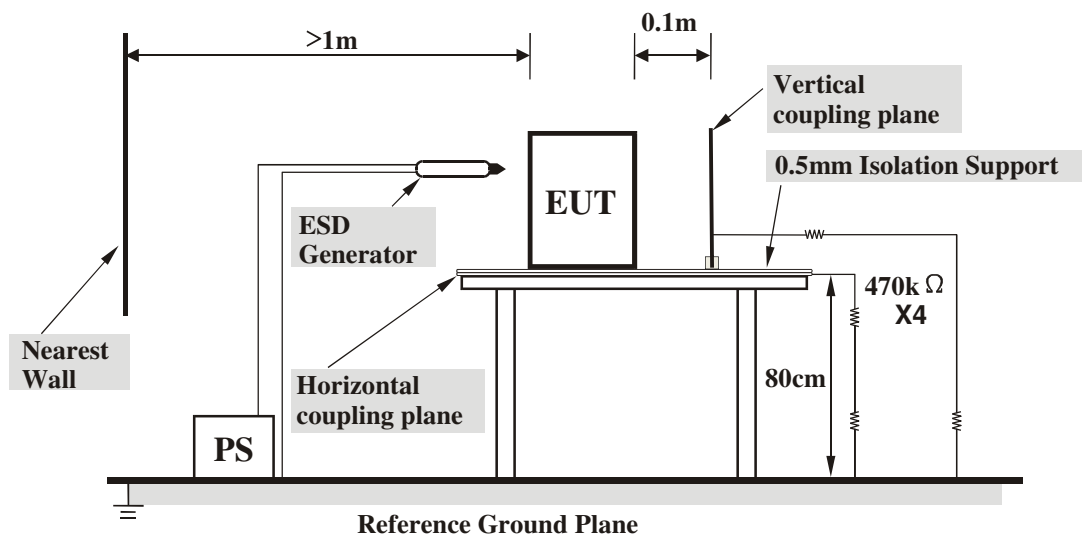

Table-top Equipment

The configuration consisted of a wooden table 0.8 meters high standing on the **Ground Reference Plane**. The **GRP** consisted of a sheet of aluminum at least 0.25mm thick, and 2.5 meters square connected to the protective grounding system. A **Horizontal Coupling Plane** (1.6m x 0.8m) was placed on the table and attached to the **GRP** by means of a cable with 940kΩ total impedance. The equipment under test, was installed in a representative system as described in section 7 of EN/IEC 61000-4-2, and its cables were placed on the **HCP** and isolated by an insulating support of 0.5mm thickness. A distance of 1-meter minimum was provided between the EUT and the walls of the laboratory and any other metallic structure.

9.4 Test Results

Input Power	230 Vac, 50 Hz (System)	Test Date	2019/1/4
Environmental Conditions	23 °C, 40% RH, 982 mbar	Tested by	Koei Chang

Test Results of Direct Application					
Discharge Level (kV)	Polarity (+/-)	Test Point	Contact Discharge	Air Discharge	Performance Criterion
2, 4	+/-	1	Note	NA	A
2, 4, 8	+/-	2	NA	Note	A

Description of test points of direct application: Please refer to following page for representative mark only.

Test Results of Indirect Application					
Discharge Level (kV)	Polarity (+/-)	Test Point	Horizontal Coupling Plane	Vertical Coupling Plane	Performance Criterion
2, 4	+/-	Four Sides	Note	Note	A

Description of test points of indirect application:

1. Front side 2. Rear side 3. Right side 4. Left side

Note: The EUT function was correct during the test.

Description of Test Points

1

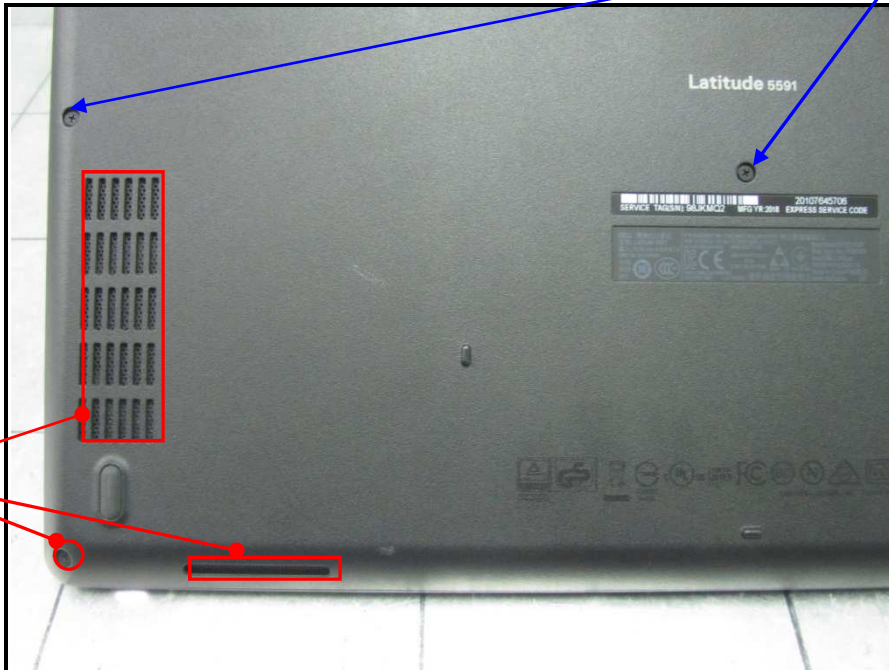

2

10 Radiated, Radio-frequency, Electromagnetic Field Immunity Test (RS)

10.1 Test Specification

Basic Standard:	EN/IEC 61000-4-3
Frequency Range, Field Strength:	80-1000 MHz, 3V/m
Modulation:	1kHz Sine Wave, 80%, AM Modulation
Frequency Step:	1 % of preceding frequency value
Polarity of Antenna:	Horizontal and Vertical
Antenna Height:	1.55m
Dwell Time:	3 seconds

10.2 Test Instruments

Description & Manufacturer	Model No.	Serial No.	Cal. Date	Cal. Due
Power Amp ROHDE & SCHWARZ	BBA 100	101761	NA	NA
Power Amp ROHDE & SCHWARZ	BBA150	101714	NA	NA
Power Sensor ROHDE & SCHWARZ	NRP-Z91	101572	Feb. 07, 2018	Feb. 06, 2019
Power Sensor ROHDE & SCHWARZ	NRP-Z91	101573	Jan. 25, 2018	Jan. 24, 2019
Signal Generator ROHDE & SCHWARZ	SMB100A	105801	Jan. 22, 2018	Jan. 21, 2019
R&S Software	EMC32 Version 9.15.03	NA	NA	NA
LOG ANTENNA Schwarzbeck	STLP9149	9149-280	NA	NA
LOG ANTENNA Amplifier Research	AT5080ANT	303730	NA	NA
Broadband Field Meter Narda	HI-6105	00212757	Jun. 05, 2018	Jun. 04, 2019

- Note:
1. The test was performed in HwaYa RS Room 1.
 2. The calibration interval of the above test instruments is 12 months and the calibrations are traceable to NML/ROC and NIST/USA.
 3. The calibration interval of Broadband Field Meter is 24 months and the calibrations are traceable to NML/ROC and NIST/USA.
 4. The transmit antenna was located at a distance of 3 meters from the EUT.

10.3 Test Arrangement

The test procedure was in accordance with EN/IEC 61000-4-3.

- The testing was performed in a modified semi-anechoic chamber.
- The frequency range is swept from 80 MHz to 1000 MHz, with the signal 80% amplitude modulated with a 1kHz sine wave.
- The field strength level was 3 V/m.
- The test was performed with the EUT exposed to both vertically and horizontally polarized fields on each of the four sides.

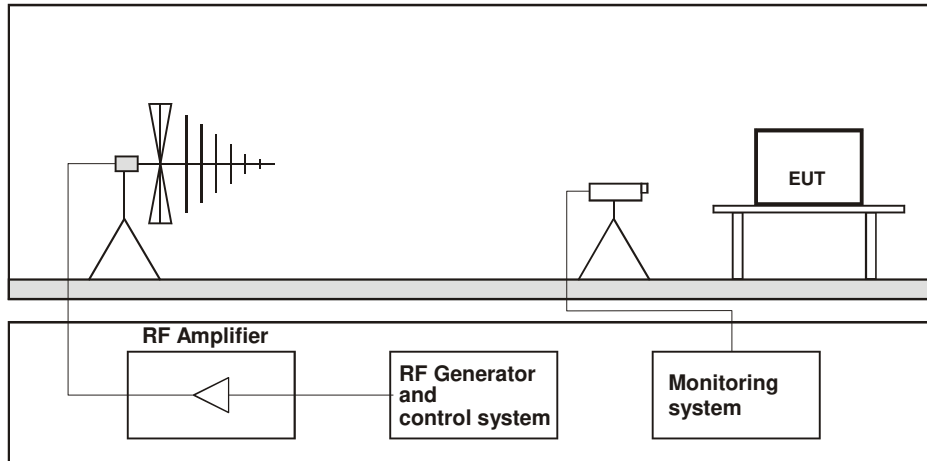

Table-top Equipment

The EUT installed in a representative system as described in section 7 of EN/IEC 61000-4-3 was placed on a non-conductive table 0.8 meters in height. The system under test was connected to the power and signal wire according to relevant installation instructions.

10.4 Test Results

Input Power	230 Vac, 50 Hz (System)	Test Date	2019/1/2
Environmental Conditions	23 °C, 60% RH	Tested by	Vison Tseng

Frequency (MHz)	Polarity	Azimuth (°)	Applied Field Strength		Observation	Performance Criterion
			(V/m)	Modulation		
80-1000	V&H	0, 90, 180, 270	3	80% AM (1kHz)	Note	A

Note: The EUT function was correct during the test.

11 Power Frequency Magnetic Field Immunity Test

11.1 Test Specification

Basic Standard:	EN/IEC 61000-4-8
Frequency Range:	50Hz
Field Strength:	1 A/m
Observation Time:	1 minute
Inductance Coil:	Rectangular type, 1mx1m

11.2 Test Instruments

Description & Manufacturer	Model No.	Serial No.	Cal. Date	Cal. Due
F.W.BELL 4190 Gaussmeter	4190	0743043	Mar. 12, 2018	Mar. 11, 2019
5KVA AC POWER SOURCE/CONDITION UNIT	NSG 1007/ CCN 1000-1	1323A00070/ 1318A02119	Oct. 15, 2018	Oct. 14, 2019
Multi turn Magnetic TESEQ	INA702/INA2141	268/1427	Oct. 15, 2018	Oct. 14, 2019

- Note: 1. The test was performed in HwaYa EMS Room 1.
 2. The calibration interval of the above test instruments is 12 months and the calibrations are traceable to NML/ROC and NIST/USA.

11.3 Test Arrangement

- The equipment is configured and connected to satisfy its functional requirements.
- The power supply, input and output circuits shall be connected to the sources of power supply, control and signal.
- The cables supplied or recommended by the equipment manufacturer shall be used. 1 meter of all cables used shall be exposed to the magnetic field.

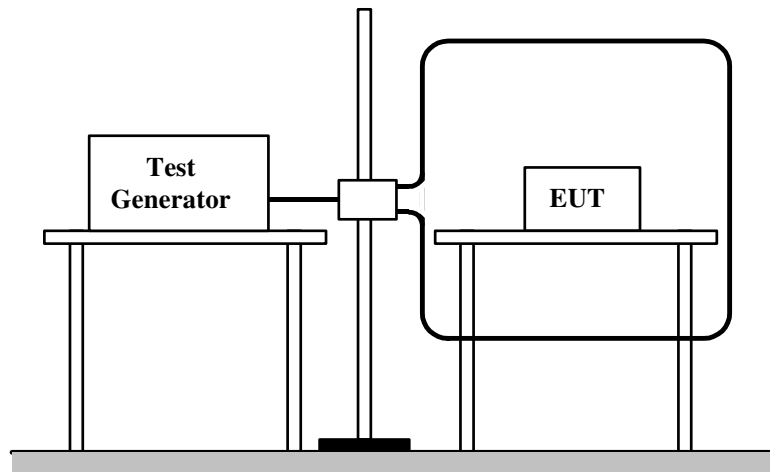

Tabletop equipment

The equipment shall be subjected to the test magnetic field (see example as above). The plane of the inductive coil shall then be rotated by 90° in order to expose the EUT to the test field with different orientations.

11.4 Test Results

Input Power	230 Vac, 50 Hz (System)	Test Date	2019/1/4
Environmental Conditions	24 °C, 58% RH	Tested by	Davis Chen

Application	Frequency (Hz)	Field Strength (A/m)	Observation	Performance Criterion
X - Axis	50	1	Note	A
Y - Axis	50	1	Note	A
Z - Axis	50	1	Note	A

Note: The EUT function was correct during the test.

12 Pictures of Test Arrangements

12.1 Conducted Emission from the AC Mains Power Port

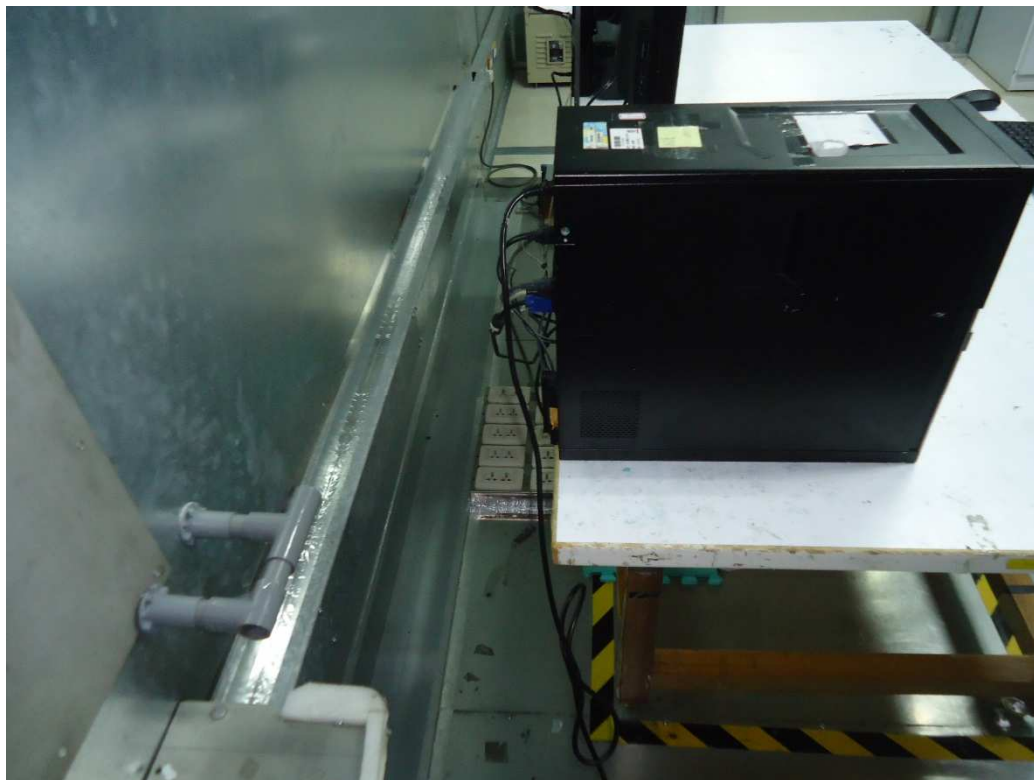

12.2 Radiated Emission at Frequencies up to 1GHz

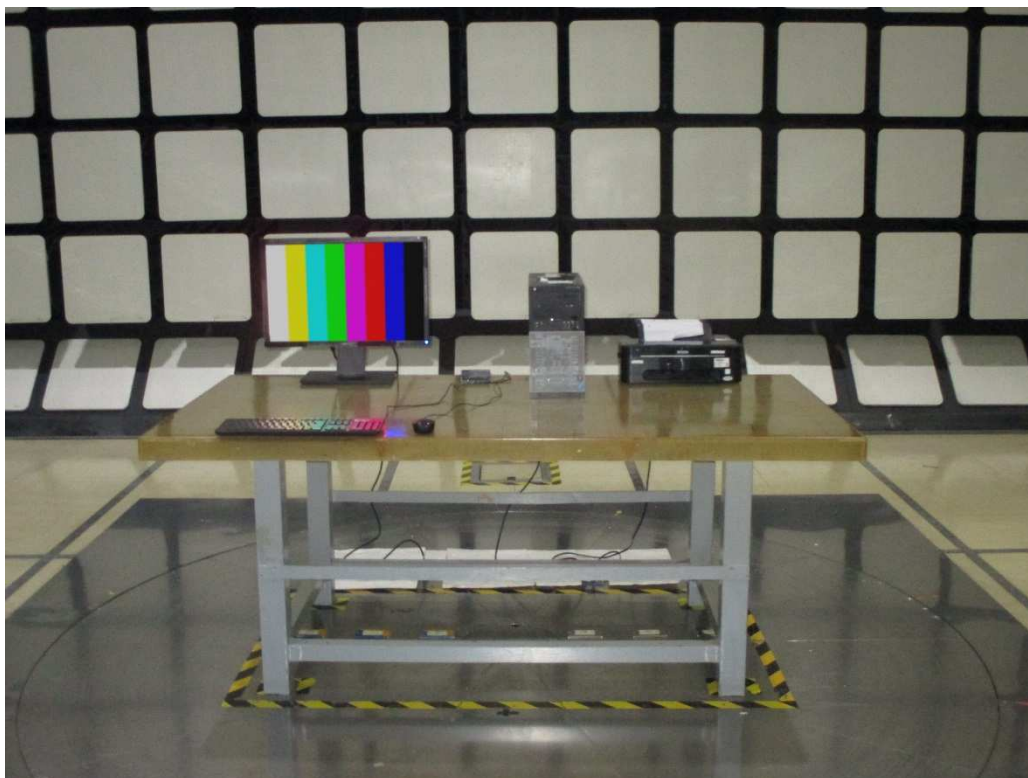

12.3 Radiated Emission at Frequencies above 1GHz

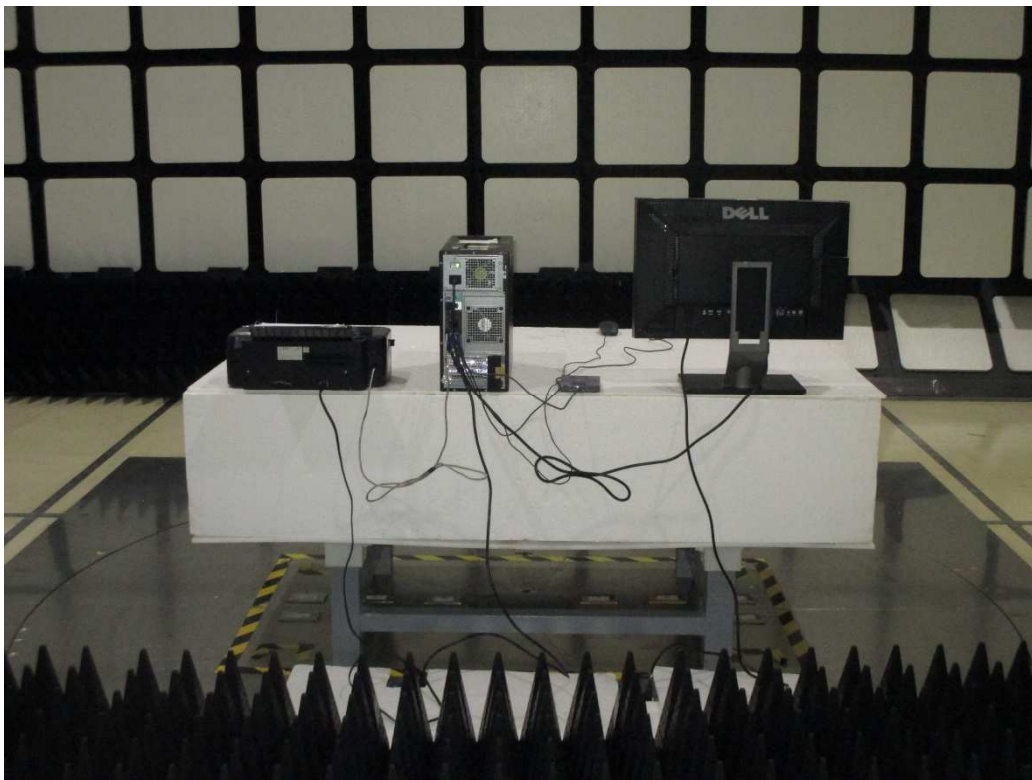
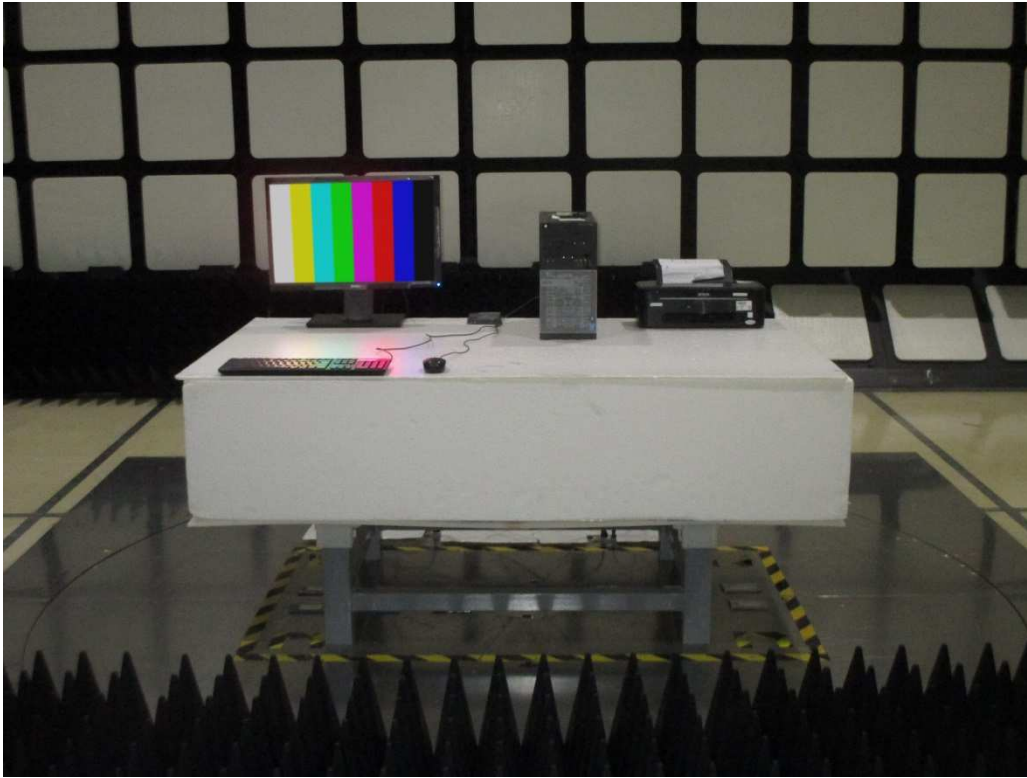

12.4 Electrostatic Discharge Immunity Test (ESD)

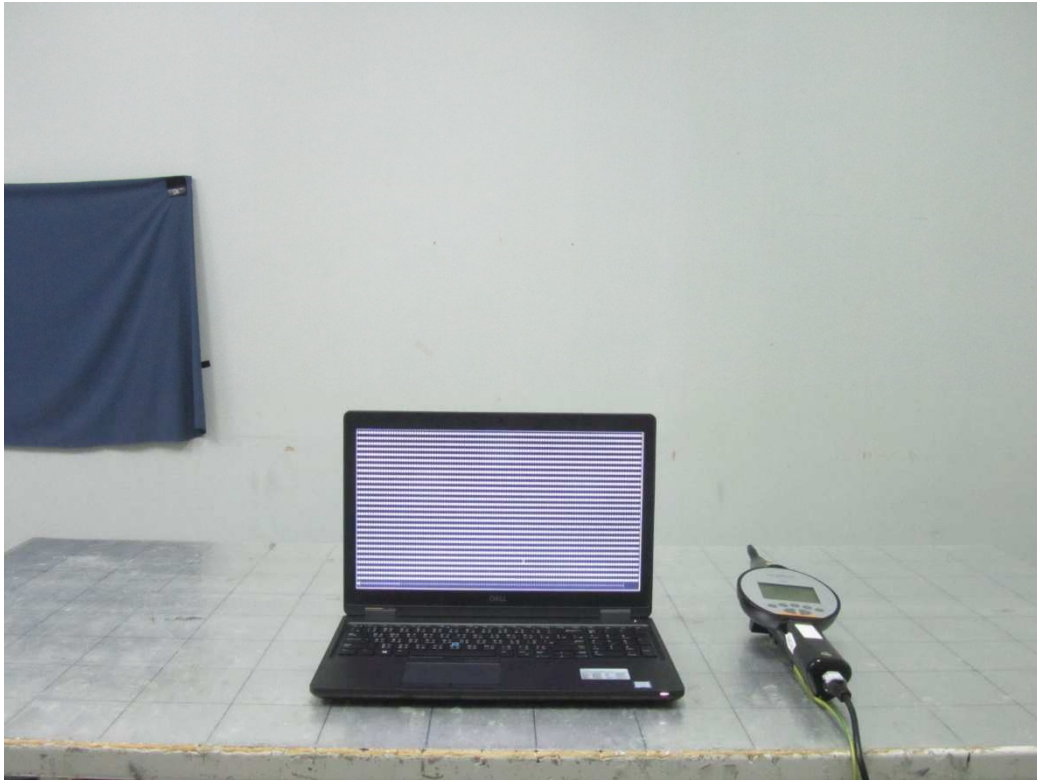

12.5 Radio-frequency, Electromagnetic Field Immunity Test (RS)

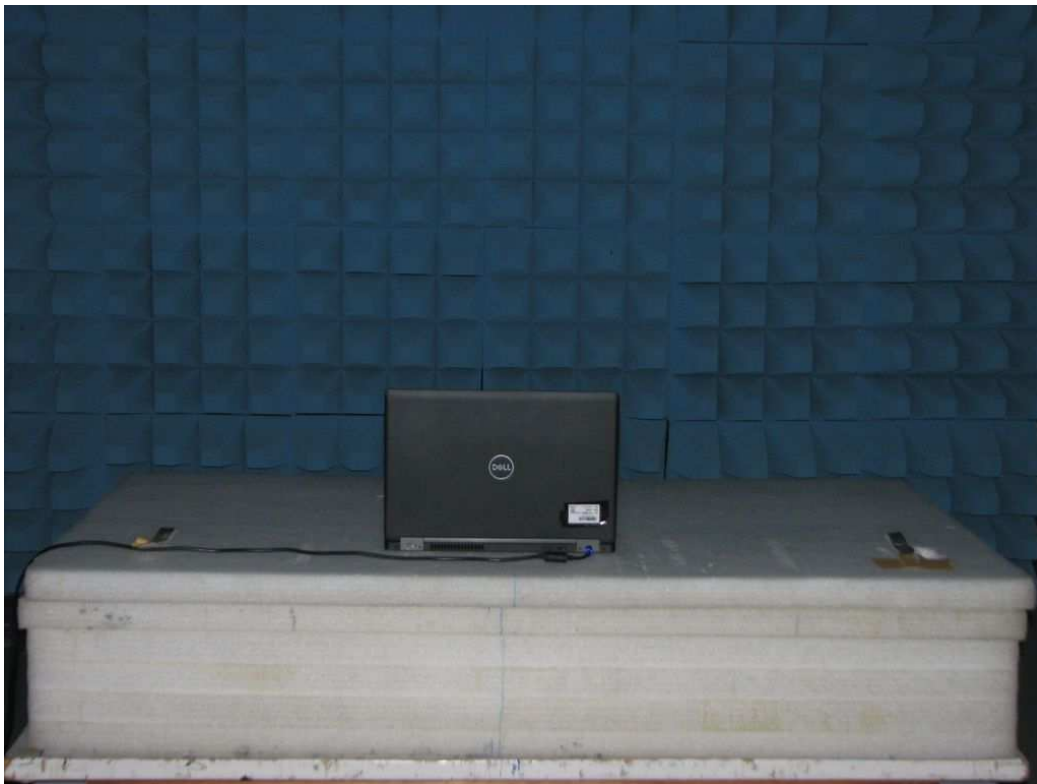

12.6 Power Frequency Magnetic Field Immunity Test (PFMF)



Appendix – Information of the Testing Laboratories

We, Bureau Veritas Consumer Products Services (H.K.) Ltd., Taoyuan Branch, were founded in 1988 to provide our best service in EMC, Radio, Telecom and Safety consultation. Our laboratories are FCC recognized accredited test firms and accredited and approved according to ISO/IEC 17025.

If you have any comments, please feel free to contact us at the following:

Lin Kou EMC/RF Lab

Tel: 886-2-26052180

Fax: 886-2-26051924

Hsin Chu EMC/RF/Telecom Lab

Tel: 886-3-6668565

Fax: 886-3-6668323

Hwa Ya EMC/RF/Safety Lab

Tel: 886-3-3183232

Fax: 886-3-3270892

Email: service.adt@tw.bureauVeritas.com

Web Site: www.bureauVeritas-adt.com

The address and road map of all our labs can be found in our web site also.

--- END ---